

SWINGAWAY ALIGNMENT ASSEMBLY

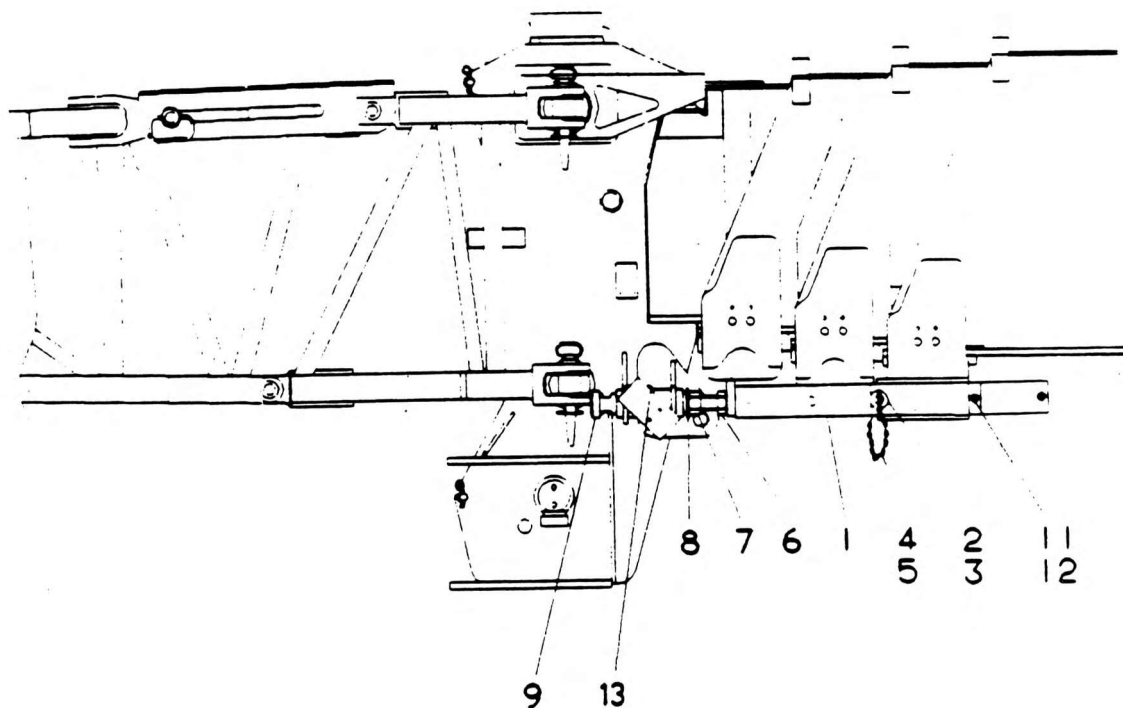

NO	PART NO	QTY	DESCRIPTION	NO	PART NO	QTY	DESCRIPTION
1	6-059-990202	1	Push Bar Weld				
2	7-689-000721	1	Pin Lock Hitch Pin				
3	7-689-000036	1	Clip Pin				
4	7-601-000253	2	Open End Link				
5	6-286-000012	1	Coil Chain				
6	7-118-344050	1	1½" UNC x 5" Cap Screw				
7	6-705-998516	1	Plate Clamp				
8	7-660-340200	1	1½" UNC Jam Nut				
9	6-059-990201	1	Pusher Bar				
11	7-112-181650	1	Bolt				
12	7-661-181600	1	Locknut ½"				
13	7-440-000000	1	Grease Fitting				

6-164-990602
Issue No. C3